

## Invited

**Highly-functional Optical Modules Using PLC Hybrid Integration Technology**

Ikuro OGAWA, and Yasumasa SUZAKI

NTT Photonics Laboratories

Tokai-mura, Naka-gun, Ibaraki-ken, 319-1193 Japan

TEL +81 29 287 7524 FAX +81 29 287 7877 E-mail ogawa@iba.iecl.ntt.co.jp

**1. Introduction**

Future photonic networks using wavelength-division-multiplexing (WDM) and time-division-multiplexing (TDM) will require various kinds of highly functional optical modules such as wavelength converters, high-speed wavelength selectors, and high-speed time-division-multiplexers. To realize these modules, it is essential to integrate passive and active functions. One of the most promising ways of achieving this is by means of planar lightwave circuit (PLC) hybrid integration technology, where optoelectronic devices are hybridized on a PLC.

This paper presents an overview of PLC hybrid integration technology and its application to highly functional optical modules.

**2. PLC Hybrid Integration Technology**

This section describes key techniques for PLC hybrid integration.

*a) PLC Platform*

We have developed a PLC platform [1] with both optical waveguide and electrical wiring functions as an optical and electrical hybrid integration platform. The platform has a silicon terrace, which works not only as a device assembly region but also as a vertical alignment plane and as heatsink for optoelectronic devices. Fast electrical wiring such as a coplanar waveguide or a microstrip line fabricated on the platform together with the micro solder bump technique allows us to achieve high speed electrical signal transmission beyond 20 GHz.

*b) Spot-size Converted Semiconductor Devices*

Optical coupling between semiconductor devices and waveguides is essential in hybrid integration, since it has a direct impact on module performance. We developed the spot-size converted (SS-) laser diode (LD) [2] and the semiconductor optical amplifier (SOA) [3], in which spot-size converters with a vertical taper are integrated with the ends to be coupled with waveguides. The SS structure greatly improves the waveguide coupling loss to about 4 dB and the 1-dB down tolerance to better than  $\pm 2 \mu\text{m}$  for the horizontal direction and  $20 \mu\text{m}$  for the axial direction.

*c) Multi-chip Bonding Technique*

We developed the two step assembly method for multi-chip integration [4]. In this procedure, first we align each chip with the waveguide by using the index alignment method and then place them successively in their optimum positions. After that, all the chips are simultaneously bonded to the platform by reflowing AuSn solder. This procedure enables us to achieve high density integration with a high alignment accuracy of  $\pm 1 \mu\text{m}$ .

*d) PLC-PLC Direct Attachment Technique*

We encounter certain problems when attempting to fabricate a large scale functional module on a single platform. They are the wafer size limitation, the difficulty of evaluating the performance of each circuit element, and the fabrication yield. To overcome these problems, we introduced a multi-platform structure using the PLC-PLC direct attachment technique [5]. Using this technique, complicated and large scale integrated modules can be simply constructed by attaching PLC elements, which are fabricated separately, without any large degradation in the optical path length deviation.

**3. Applications**

Table I lists examples of the highly functional modules achieved by using PLC hybrid integration technology. The following briefly reviews two recent achievements.

*a) High-speed Optical Wavelength Selector*

Figure 1 shows the schematic configuration of 32-ch high-speed optical wavelength selector (OWS) module [6] which enables us to pick out arbitrary

Table I Examples of hybrid integrated modules

Functional Elements		Optical Modules
Active	Passive	
DFB-LD	MMI	Multi-wavelength light source
SS-LD	UV-grating	Multi-wavelength light source
SS-SOA	MZI AWG delay line	Wavelength converter Wavelength selector Time-division-multiplexer
WG-PD	delay line	Differential receiver
PD	AWG	Multi-wavelength receiver

optical packets with given wavelengths from a multiplexed signal by turning on the corresponding optical gate switches. The module was fabricated by directly attaching two arrayed waveguide gratings (AWGs) and an optical gate array (OGA) circuit. The OGA employs 8 chips of 4-ch SS-SOA gate array. Optical delay lines are also formed on the OGA platform to synchronize the bit by bit timing among the optical packets.

Figure 2 shows the measured transmission spectrum of the module. We obtained good levels of performance, namely an average insertion loss of 2.3 dB with a low crosstalk of better than -40 dB at an SS-SOA injection current of 70 mA and an input optical power of 1 dBm. The relative optical delay among channels was better than  $\pm 6$  ps and we achieved a fast switching time of 1 ns.

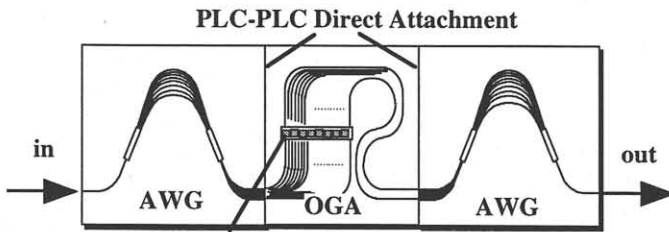

Fig. 1 32-ch OWS module

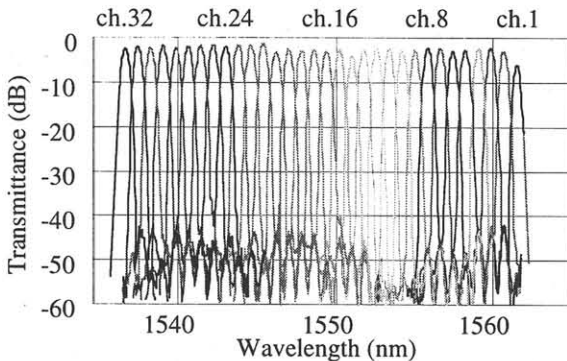

Fig. 2 OWS module transmission spectrum

*b) All-Optical Time-Division-Multiplexer*

Figure 3 shows the configuration of an 80 Gb/s (20 Gb/s x 4) all-optical time-division-multiplexer [7]. The module consists of two 1 x 4 MMI couplers, four 2 x 1 combiners, and four optical delay lines with a relative delay of 12.5 ps between neighboring channels. A 4-ch SS-SOA array chip is mounted in the middle of the delay lines. The operation of the module is as follows. A 20 GHz optical clock and four 20 Gb/s modulation signals are input into given ports as shown in the figure. They are combined with a 2 x 1 combiner, and then launched into corresponding SS-SOAs to generate four-wave-mixing (FWM) components. Finally the FWM components are combined and output as a TDM signal.

The module provided stable TDM multiplexing as

shown in Fig. 4 by using the all-optical modulation scheme which eliminates the microwave crosstalk between adjacent channels. The result indicates the excellence of PLC hybrid integration technology.

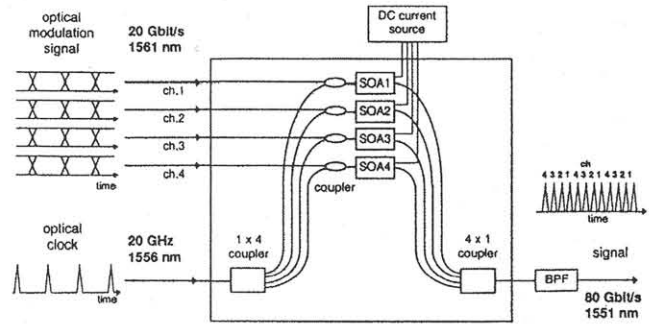

Fig. 3 All-optical time-division-multiplexer

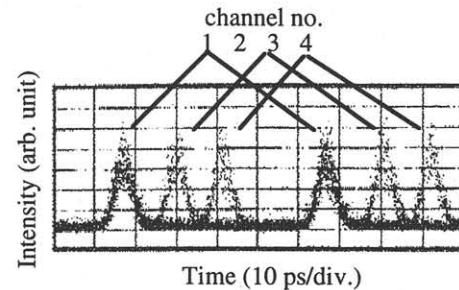

Fig. 4 Measured waveform (ch. 2 is all space)

**4. Conclusion**

We described PLC hybrid integration technology and its applications. This technology enables us to integrate passive and active optical functions together with fast electrical functions. Moreover, the multi-platform scheme using the PLC-PLC direct attachment technique offers a practical way of achieving a large scale integration. These promising features show its great potential for realizing the wide variety of highly functional modules required for future photonic networks.

**Acknowledgments**

The authors thank Drs. S. Tohno, T. Miya, H. Iwamura, K. Kato, N. Ishihara, A. Himeno, Y. Ohmori, Y. Tohmori, H. Takeuchi and Y. Yoshikuni for their continuous support and encouragement. They also thank Drs. H. Takara and I. Shake for their contribution to this work.

**References**

- [1] Y. Yamada, et al., *Electron. Lett.*, vol. 29, pp. 444-445, 1993.
- [2] Y. Tohmori, et al., *Electron. Lett.*, vol. 31, pp. 1069-1070, 1995.
- [3] N. Yoshimoto, et al., *Electron. Lett.*, vol. 33, pp. 2045-2046, 1997.
- [4] T. Hashimoto, et al., *J. Lightwave Technol.*, vol. 16, pp. 1249-1258, 1998.
- [5] I. Ogawa, et al., *OFC'98 Postdeadline Papers*, PD4, 1998.
- [6] F. Ebisawa, et al., *OFC'99*, ThB1-1~3, 1999.
- [7] H. Takara, et al., *OFC'99*, FI2-1~3, 1999.